

A5020 FLUXGATE COMPASS USER MANUAL

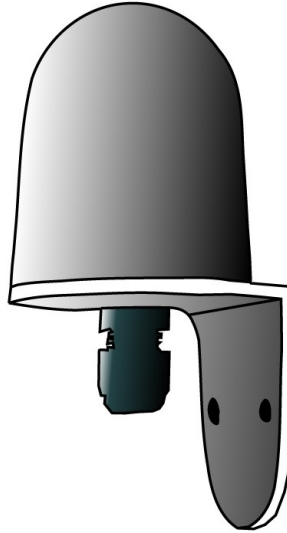

A5020 manual 06-07.doc
Hardware version 1.1
Software release 0.0.8

Software releases:

- 0.0.5 Initial
- 0.0.6 HDT added
- 0.0.7 other output sentences added
- 0.0.8 power-up delay and LED off commands added

Hardware versions:

- V 1.0 Initial production
- V 1.1 Change to cable

Table of Contents

1 Introduction and description of fluxgate compass.

- 1.1 Description of compass
- 1.2 Connections
- 1.3 Switches
- 1.4 Indicator light
- 1.5 Power supply.
- 1.6 Mounting

2 Connecting the compass to your application.

- 2.1 To a NMEA-0183 instrument.
- 2.2 To a PC serial port.

3 Output formats available from compass.

- 3.1 NMEA-0183
- 3.2 Furuno AD-10

4 Calibrating the compass.

- 4.1 Why the compass needs calibrating.
- 4.2 Starting calibration.
- 4.3 Aborting a bad calibration.
- 4.4 Setting reference NORTH heading
- 4.5 Set-up suggestions

5 Configuration

6 References

1. Introduction and description of fluxgate compass.

1.1 Description of compass.

The Autonnic NMEA compass unit is a complete component for a compass indicating system, RADAR 'North-up' input or autopilot. It is housed in a water-resistant enclosure so it can be mounted outside a steel hull. It delivers heading data in two industry-standard forms. .

The A5020 contains a fluxgate with floating core surrounded by high-precision interface circuits which, together with the special clockwise/anticlockwise and offset nulling sequence allow a microprocessor to acquire a binary value from two orthogonal sensors of the horizontal component of the Earth's magnetic field. The processor calculates the vector from these values, uses a calibration table to correct for local field disturbance errors, offsets the result and then presents the data in a manner which has been requested. Such requests alter the frequency of the data, the degree of filtering and the offset value. Calibration sequences can also be commanded.

1.2 Connections

Conductor	Colour	Type	Function
1	Red	P	+Supply 8-30v
2	Yellow	O	Furuno AD-10 Clock
3	Brown	I	NMEA IN-
4	White	I	NMEA IN+
5	Black	P	GND
6	Green	O	NMEA OUT+
7	Blue	P	GND
8	Violet	O	Furuno AD-10 Data
9	Screen	P	GND

NOTE Conductors 5, 7 and 9 are connected together inside the A5020

1.3 Switch Inputs

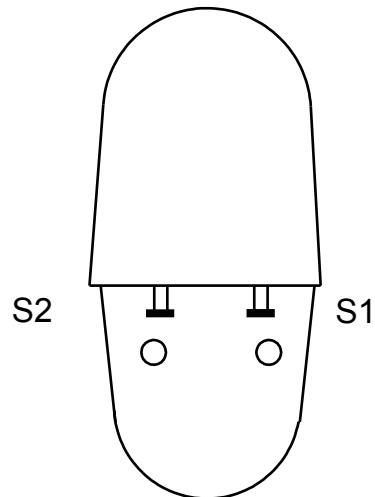

Fig 1

Two push-button switches are provided to enable the user to calibrate the compass in the field.

When the A5020 is viewed from the front face with the LED facing, then Switch 1 is on the right and Switch 2 is on the left.

- | | | |
|---|---------------|---|
| 1 | Switch 1: | Start the auto-calibration process |
| 2 | Switch 2: | Set reference NORTH heading. The A5020 must be mounted upright but at any azimuth. Pressing S2 sets the heading to zero and so can be done when the whole installation is headed North. |
| 3 | Both together | Pressing both together for at least one second causes the auto-calibration process to halt and restores the previously saved calibration values. |

1.4 Indicator light

A blue light indicates three states of the A5020.

State 1	Uncalibrated	long flash
State 2	In the process of calibration	continuous
State 3	Calibrated	short flash

After the reset command, `$PATC, I IHDG, 0 CV<CR><LF>`, the A5020 is uncalibrated and will have a long flash.

Note that the LED can be turned off and on by the DLED command – see section 5.

1.5 Power supply

The compass is compatible with any DC power supply of between 8 and 30 Vdc. Typical supply current during operation is approx. 25mA. The compass is protected against reversed polarity.

Note that the operation of the LED adds another 10mA and that during autocalibration the consumption can be as high as 60mA.

Care should be taken to make sure the compass is not situated too close to the power supply, as it's accuracy may be affected by either the iron in the mains transformer, or by magnetic field 'noise' from a switching power supply. It is not possible to cover all possible scenarios here, and it remains up to the user to determine the suitability of a possible location for the compass.

Note that the output from the A5020 takes several seconds to stabilize after a power is applied; the time taken depends on the damping settings. There is a command - see section 5 – which can be used to suppress the output after power-up.

1.6 Mounting

The compass is fixed to the chassis of the vessel or vehicle in the upright position using the fixing holes shown in the data sheet. It does not matter which way it faces as the azimuth can be set to North at any time the chassis is orientated North. Alternatively if the azimuth of the chassis is known, then the A5020 may be rotated before fixing to North using a protractor. S2 is then pressed and then the compass can be mounted on the chassis.

2 Connecting the compass to your application

2.1 Compass to a NMEA-0183 instrument

The hardware on which the NMEA-0183 standard is based on is a balanced serial protocol called RS422. This means that two wires are need for send and two for receive.

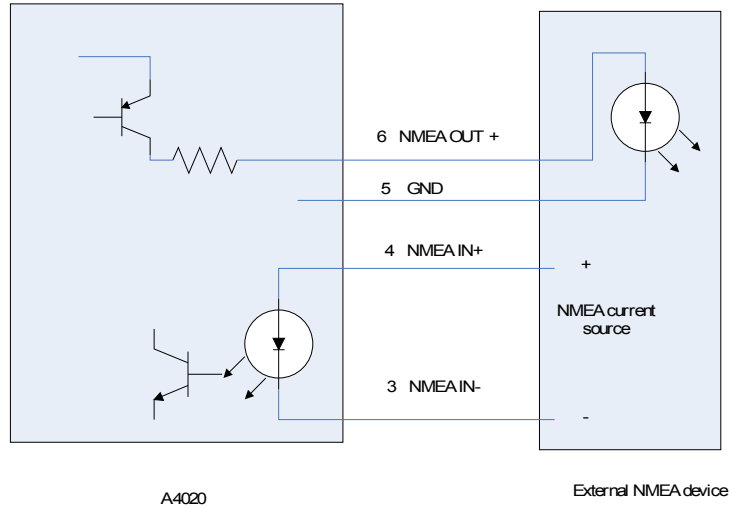

Fig 2

The current in the A4020 is sourced from +5v. Note that the GND wire is used for the current return path. This might be shared with the NMEA- wire in some installations.

2.2 Compass to a PC serial port

In many cases the wires can be joined directly as shown in Fig 2. Alternatively use the Autonnac A3036 serial interface unit.

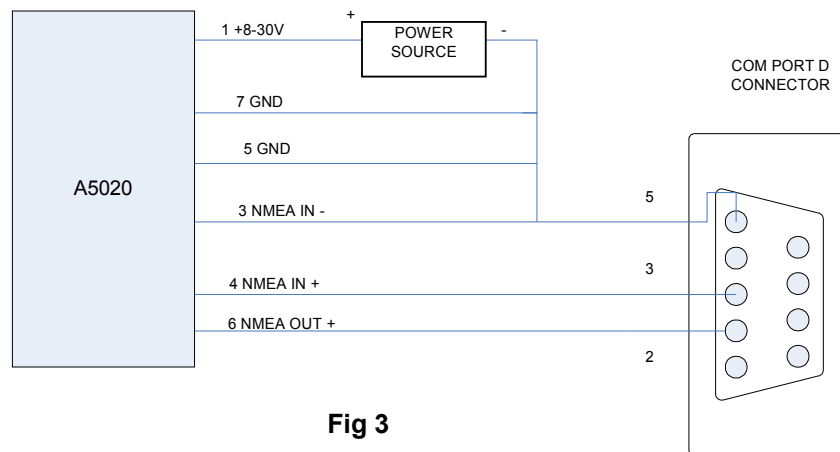

Fig 3

3 Output formats available from compass

3.1 NMEA-0183

The serial output format is: 4800 Baud, 8 data bits, 1 stop bit, no parity.

The compass sends information using the standard NMEA-0183 sentence 'HDG': Magnetic Heading, Deviation, and Variation. But note that the information of Deviation and Variation is not sent and so blank fields are defined by consecutive commas. In the A5020 the sentence may have one of several forms typically of the general form:

\$HCHDG, hhh.h etc

Where hhh.h is the magnetic heading from 000.0 to 359.9 degrees

For a complete list of output formats available see Section 5

3.2 Furuno AD-10

The compass has a separate, dedicated output in Furuno AD-10 format. This is a proprietary 4 character serial format, which gives heading in degrees and tens of minutes. The string 0872 represents the heading 87° 20' so that the precision is to 1/6 of a degree. At the same time the A5020 would be also sending the NMEA data to a precision of 1/10 of a degree.

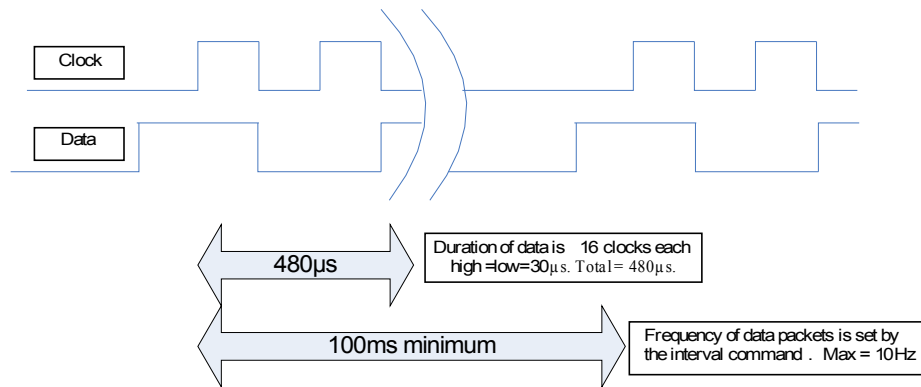

Fig 4

4 Calibration

4.1 Why the compass needs calibrating

When any compass is installed the magnetic characteristics of the whole installation affect the way the Earth's field reaches the detector inside the device. Each individual installation will be different and so the A5020 is equipped with an auto-calibration routine which corrects for these installation distortions.

4.2 Starting calibration

- A NMEA-0183 command can be sent to initiate the process.
- OR
- Switch 1 can be pressed to start it.

There are two compass calibration techniques in common use:

- 1 Constant angular velocity
- 2 Double rotation without constant velocity.

The A5020 uses the first method. The process consists of rotating the whole installation in the Earth's field so that both permanent magnets and induced magnets are corrected. The method used is the single turn at a constant rate and this rate should be in range 60 to 180 seconds for the full 400 degrees needed. The whole arrangement is turned at constant angular velocity because the method relies on applying a correction when the heading measured is uneven with time.

The second method is not used in the A5020. Autonnic has evaluated the method which uses a mathematical model of an ideal compass and treats errors as arising from distortion due to magnetic objects. The ideal error plot of the field vector would be a circle with no offset from the origin. Permanent magnets ('hard') have the effect of shifting the centre from the origin and induced magnets ('soft') modify the circle into an ellipse. The results of our investigation show that there is always a residual error due to the fact that real magnetic objects do not behave exactly according to the model outlined. Autonnic is aware that the need for a constant angular velocity is onerous but the benefit is that it provides a very low residual error – less than 0.5°.

Note that the calibration is different if the unit is mounted upside-down.

Calibration must always be done with the unit in its final mounted position. The essential point of the calibration is remove the influence of external magnetic components in the vicinity – the nearby pieces of iron and steel –so it is essential that these remain unchanged after calibration. If any significant iron component is altered – such as the installation of new equipment or replacement of equipment such as winches or engines – then the calibration must be re-done.

4.3 Terminating a bad calibration

If the process is faulty in any way – such as would happen if the manoeuvre cannot be completed, the process can be terminated by the NMEA command listed and the original factory default (linear) table is restored. Alternatively this can be done by pressing both Switches together for at least 1 second.

NOTE that there should be a delay of at least 5 seconds after termination before a new calibration process is initiated.

4.4 Setting reference NORTH heading

Switch 2 (and also a NMEA command) is provided to set 'zero'. The A5020 should

- a. first be autocalibrated
- b. then be aligned to North

4.5 Set-up suggestions

When the A5020 is fixed in place and connected it can be calibrated as described above. Choose a calm day and a region of water where there are no currents. Set the boat turning to left or right at a slow rate and fix the wheel or tiller. Then, when the turning is steadily under way, press the auto-calibrate button and watch the LED.

When calibration is completed the boat can be on its way and the next task is to set North. This is best done by identifying transits on a chart and heading the boat on the transit. Again this should be done in the same conditions so that the heading can be lined up on the transit and maintained while the set-zero button is pressed.

5 NMEA-0183 inputs

The compass can be configured by sending various proprietary sentences to its NMEA-0183 input. Once configured, the compass will remember those settings every time it is powered up.

Response:

When any of the following input sentences are received the A5020 will reply with an 'acknowledge' output sentence of the format:

```
$PATC ,HCHDG ,ACK<CR><LF>
```

Start Auto-Calibration

```
$PATC ,IIHDG ,IAC<CR><LF>
```

Refer to section 4.2. Same as pressing Switch 1 – see 4.4.

Abort Auto-Calibration.

```
$PATC ,IIHDG ,XCL<CR><LF>
```

Refer to section 1.3.

Set power-on delay

\$PATC,IIHDG,DLY,p.p<CR><LF>

Sets the period after power up during which the heading field in the NMEA sentence will be omitted.

Where p.p is the period value in seconds, 0 to 9.9 (entering larger periods will result in truncated values) [i.e. if enter 12.4, 2.4 will be accepted as the period value].

Note : same applied after calibration process.

Default: period = 0 second.

Request the serial number.

\$PATC,IIHDG,RID<CR><LF>

A special proprietary reply sentence follows:

\$PATC,WIHDG,RID,ssss<CR><LF> where ssss is the serial number in ASCII decimal.

Configure the output sentence structure and type.

\$PATC,IIHDG,CFG,ab<CR><LF>

[Replies with the standard acknowledge sentence **\$PATC,HCHDG,ACK<CR><LF>**.]

Where 'a' is sentence type as follows:

a=0 : **\$HCHDG,hhh.h,,,,<CR><LF>**

a=1 : **\$HCHDT,hhh.h,T<CR><LF>**

a=2 : **\$HCHDM,hhh.h,M<CR><LF>**

a=3 : **\$HCHCC,hhh.h<CR><LF>**

a=4 : **\$HEHDT,hhh.h<CR><LF>**

hhh.h is the compass heading in degrees

(this compass heading field will be omitted when auto-calibration in process)

and 'b' is sentence end structure as follows:

b=0 : direction sentence will NOT include checksum nor unit ID serial number.

e.g. **\$HCHDG,hhh.h,,,,<CR><LF>**

b=1 : direction sentence will include a checksum.

e.g. **\$HCHDG,hhh.h,,,,*cc<CR><LF>** (cc is the checksum)

b=2 : include the serial number.

e.g. **\$HCHDG,hhh.h,,,,*ssss<CR><LF>** (ssss is the unit's serial number)

6 References

- 1 A5020 data sheet
- 2 NMEA-0183 specification

Autonnic and the *A logo and Fluxgateworld are registered Trade Marks of Autonnic Research Ltd
©2006 - 2010

Autonnic Research Ltd Tollesbury Essex CM9 8SE UK

www.autonnic.com www.fluxgateworld.com