



ENCLOSED COMPASS



FEATURES

- Complete Compass
- IP66
- NMEA-0183
- Furuno / SPI
- 2 Axis Tilt compensation to 45°
- 8-30 V Supply
- Rich command set
- Auto calibration button
- Set zero button

APPLICATIONS

- Marine and Vehicle Compass
- Radar “North up”
- Autopilots

ABSOLUTE MAXIMUM RATINGS

PARAMETER	DESCRIPTION	NOTES	CONDITIONS	VALUE	UNIT
Θ_{STOR}	Storage Temp Range			-20 to +100	°C
Θ_{OPER}	Operating Temp Range		Vcc = 12v	0 to +65	°C
	Shock Resistance		Single impact	±40	G
	Vibration Resistance		60Hz, 10 Minutes	±11	G
V _{CC}	Supply Voltage		At 40degC	30	Vdc
P _{MAX}	Operating Pressure Range	4		-0.5 to +1	Bar

PERFORMANCE

PARAMETER	DESCRIPTION	NOTES	CONDITIONS	MIN	TYP	MAX	UNIT
t _{PU}	Time to valid output	3	After power-on			4	s
ERR _{OP}	Output error	1	heel of 0°		0.3	1	Degrees
	Output Change With Tilt	2	heel of 35°			2	
		2	heel of 45°			4	

- Notes:
- 1 After auto-calibration with original error not more than 20degrees.
 - 2 In addition to error at 0 degrees of tilt
 - 3 There is a command to delay data until after this time
 - 4 Can be shipped at 0Bar

ORDER INFORMATION

PART	DESCRIPTION	SHIPPING WEIGHT
A5020A	Enclosed Compass 15m cable	1.0kg
A5020B	Enclosed Compass 7.5m cable	500g
A5020C	Enclosed Compass no cable	120g



ELECTRICAL CHARACTERISTICS AT 20°C

PARAMETER	DESCRIPTION	NOTES	MIN	TYP	MAX	UNIT
V _{CC}	Supply Voltage		8	12	30	Vdc
I _{CC}	Current consumption			25		mA
	NMEA Output Load			4		NMEA loads
I _{O(max)}	Furuno output load	Data and clock			1	mA

NMEA-0183 OUTPUT FORMAT (software subject to change)

The output from the compass is a standard NMEA-0183 sentence which can be configured to be in one of several standard forms: Eg: \$HCHDG, hhh.h, , , , , *ss<CR><LF> or \$HCHDT, hhh.h, T<CR><LF>

where hhh.h represents the magnetic heading with one decimal place of precision, i.e: 000.0 to 359.9 degrees. The two HEX digits, ss, are a checksum. Serial output is RS422, 4800 Baud, 8 data bits, 1 stop bit, no parity.

The compass may be configured via several proprietary input sentences, and will reply with an 'Acknowledge' output sentence \$PATC, HCHDG, ACK <CR> <LF> when any of the sentences listed below are received:

COMMAND EXAMPLES

```
$PATC, IIHDG, IAC (or XCL<CR><LF>
$PATC, IIHDG, 0CV <CR><LF>
$PATC, IIHDG, AHD, fff.f<CR><LF>
$PATC, IIHDG, DHD, ddd.d<CR><LF>
$PATC, IIHDG, TXP, mmmm<CR><LF>
```

and others

FUNCTION

Start (or stop) auto-calibration
 Reset all calibration data to factory default
 Set reference heading (f = 0 to 359.9 degrees)
 Set heading damping (d = 0 to 100.0%)
 Set NMEA-0183 output period in milliseconds.
 (in range m=100 to 3000 mSec- default is 100 mSec)

Which control **LED on/off, sentence structure, checksum, serial number, autocal status and power-up delay.**

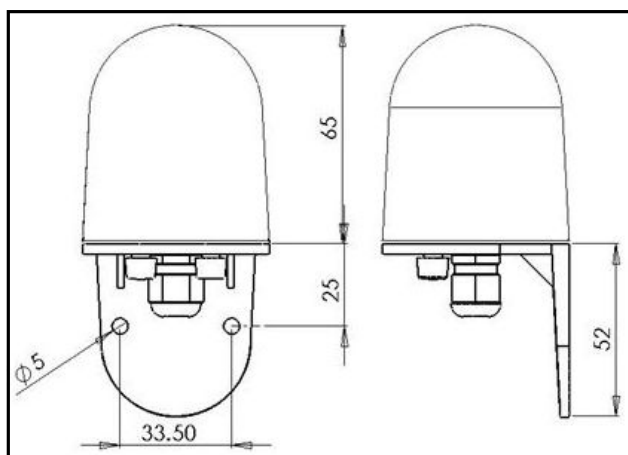

CONNECTIONS

- | | | |
|----------|---|--------------|
| 1 Red | power | +8-30v |
| 2 Yellow | output | Furuno Clock |
| 3 Brown | input | NMEA IN- |
| 4 White | input | NMEA IN+ |
| 5 Black | signal | GND |
| 6 Green | output | NMEA OUT+ |
| 7 Blue | power | GND |
| 8 Violet | output | Furuno Data |
| 9 Screen | - connected inside A5020 to Black and to Blue | |

Cable is DEF-STAN 61-12 part 4 type 7-2-8C

FLUXGATE WORLD®